



Deutsch-Brasilianische Wirtschaftstage 2008
Encontro Econômico Brasil-Alemanha 2008

Organization:



Cooperation:



Workshop 3

Development of chemical products on base of new resources

Prof. Michael Dröscher
Evonik Degussa GmbH, Essen

Cologne, 25. 08. 2008

Biotechnology, today a core competence of Evonik....



Deutsch-Brasilianische Wirtschaftstage 2008
Encontro Econômico Brasil-Alemanha 2008



Biocatalysis



Fermentation



Bioalcohol

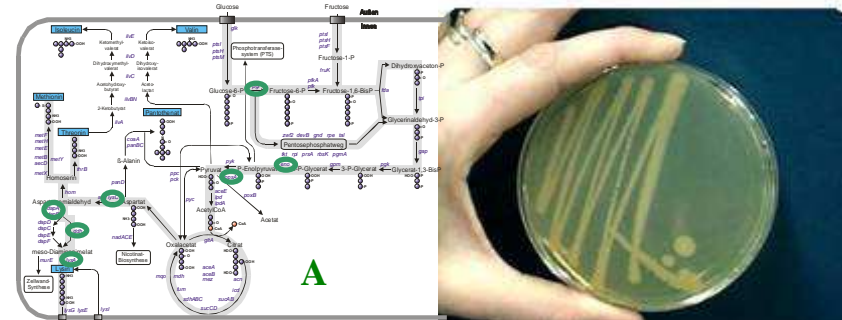

Microbiology

Biotechnology has many advantages.....



Deutsch-Brasilianische Wirtschaftstage 2008
Encontro Econômico Brasil-Alemanha 2008

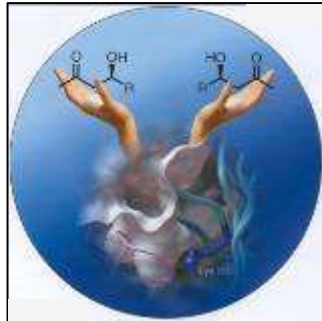

Selectivity

Diversity

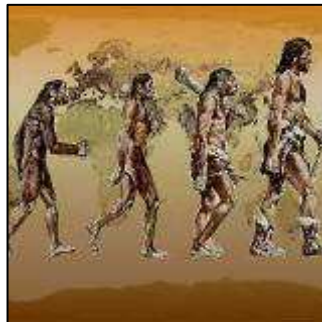
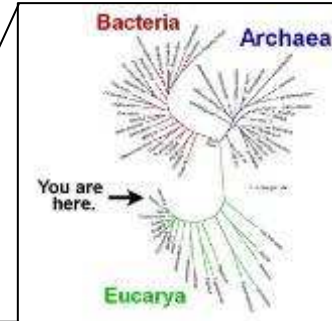

Evolvability

Robustness

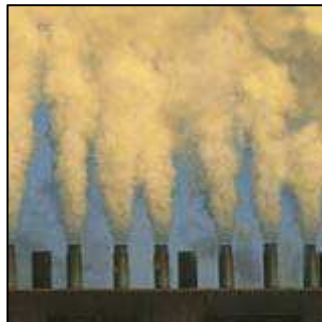
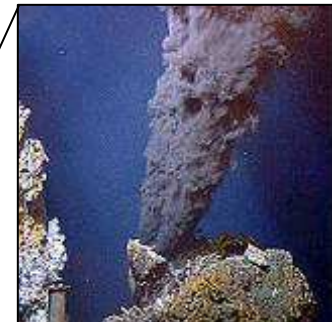

Sustainability

Biocompatibility





..and is also commercially feasible

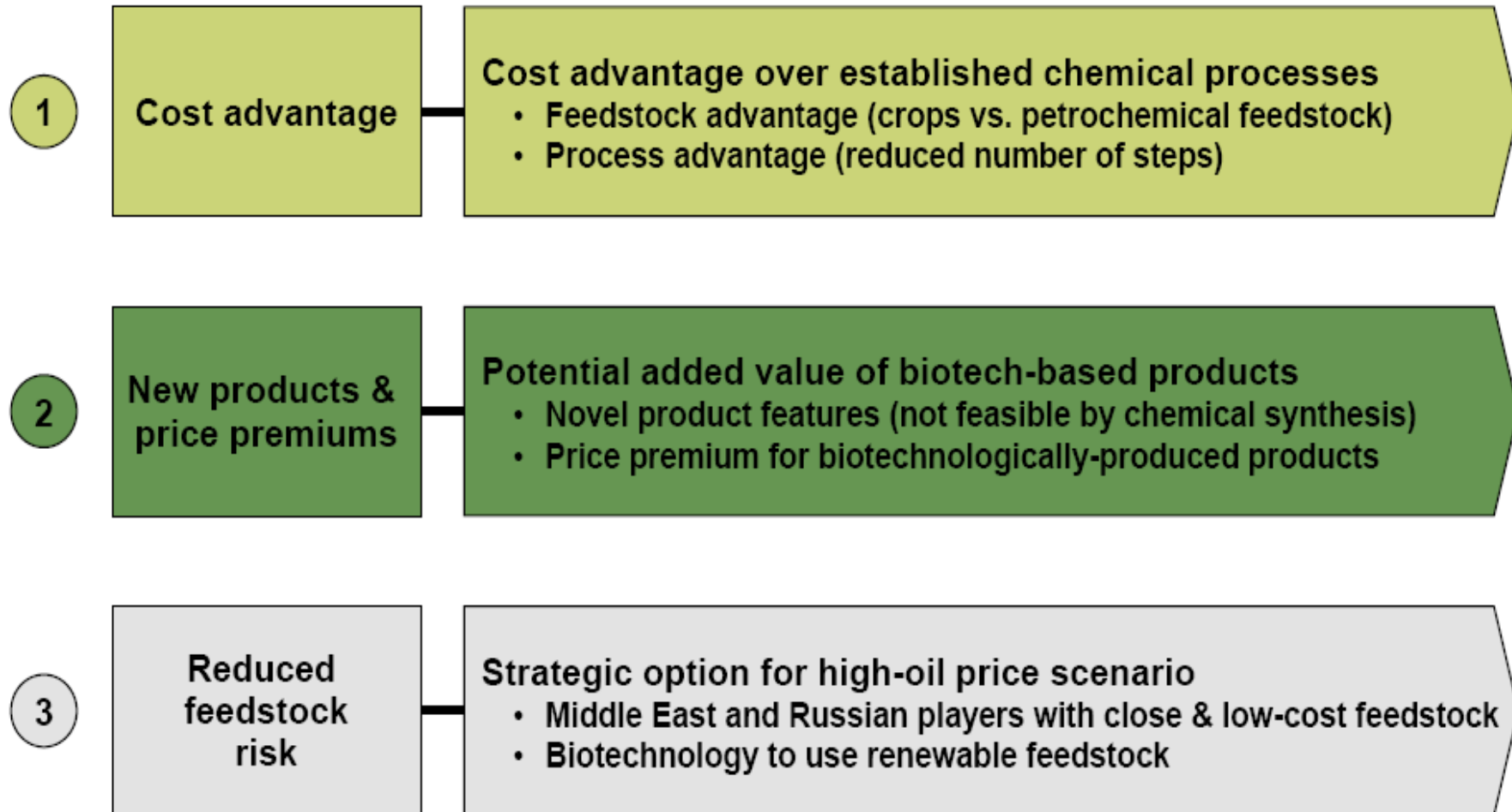

cp. BCG-Analysis, BioDeg STC 2 Presentation-7Aug07, P. 4

Success factor I: Competitive raw materials



Deutsch-Brasilianische Wirtschaftstage 2008
Encontro Econômico Brasil-Alemanha 2008

Petrochemicals



		Production	Price	C	H	O	Carbon
Ethylene	C_2H_4	110 mio t/a	1597 \$/t	86%	14%		1857 \$/t C
Propylene	C_3H_6	75 mio t/a	1436 \$/t	86%	14%		1670 \$/t C
Benzene	C_6H_6	45 mio t/a	330 \$/t	92%	8%		1446 \$/t C
Naphtha	C_nH_{2n}		1040 \$/t	86%	14%		1209 \$/t C

BioRenewables



		Production	Price	C	H	O	Carbon
Sucrose	$C_{12}H_{22}O_{11}$	170 mio t/a	232 \$/t	42%	6%	52 %	552 \$/t C
Corn-Glucose	$C_6H_{12}O_6$	330 mio t/a	268 \$/t	40%	7%	53%	670 \$/t C
Glycerol	$C_3H_8O_3$	0.8 mio t/a	465 \$/t	39%	9%	52%	1192 \$/t C

Prices as of June, 2008, 1 € = 1.55 US\$,

Sources: Naphtha Europe - ICIS; Propylene Europe Contract - ICIS; Ethene Europe Contract – ICIS; Benzene Europe – ICIS; Sugar # 11 – ICE; Glycerol Crude (80%) Europe – Oleoline; Glucose in Corn (65%) – CBOT.

Success factor II: Cutting-edge science & technology



Deutsch-Brasilianische Wirtschaftstage 2008
Encontro Econômico Brasil-Alemanha 2008

Example L-lysine

Lysine Fermentation Technology Performance in Industrial Production

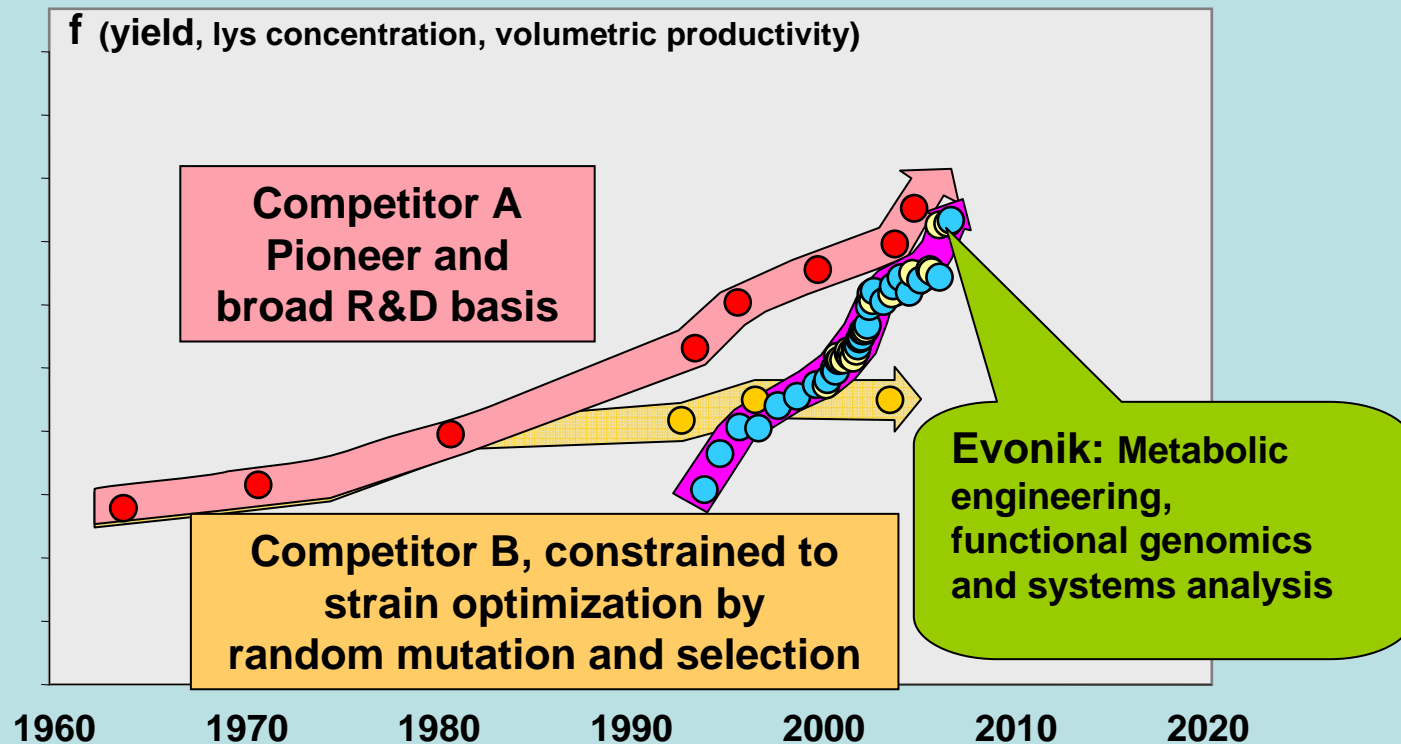
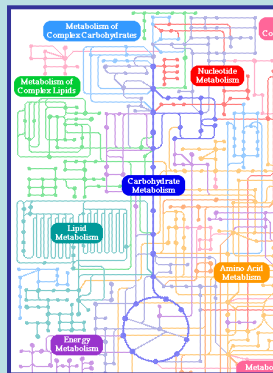

Success factor III: Solid intellectual property in key areas



Deutsch-Brasilianische Wirtschaftstage 2008
Encontro Econômico Brasil-Alemanha 2008

Example L-lysine

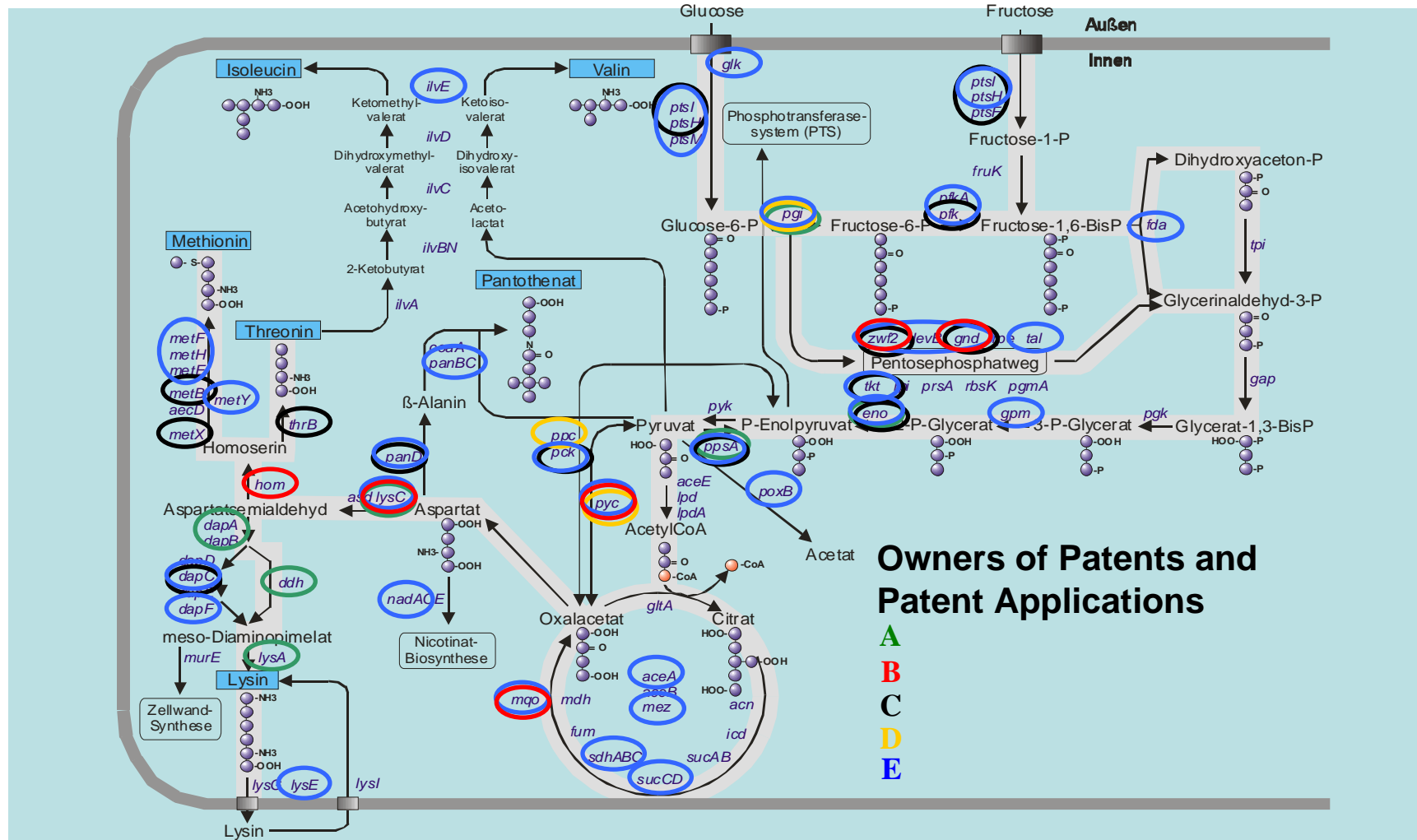

Success factor IV: Relevant lead markets stimulate disruptive power



Deutsch-Brasilianische Wirtschaftstage 2008
Encontro Econômico Brasil-Alemanha 2008

Example amino acids



Rexim s.a.; France



Fermas s.r.o.; Slovakia

Amino Acids: Introduction of BioProcesses

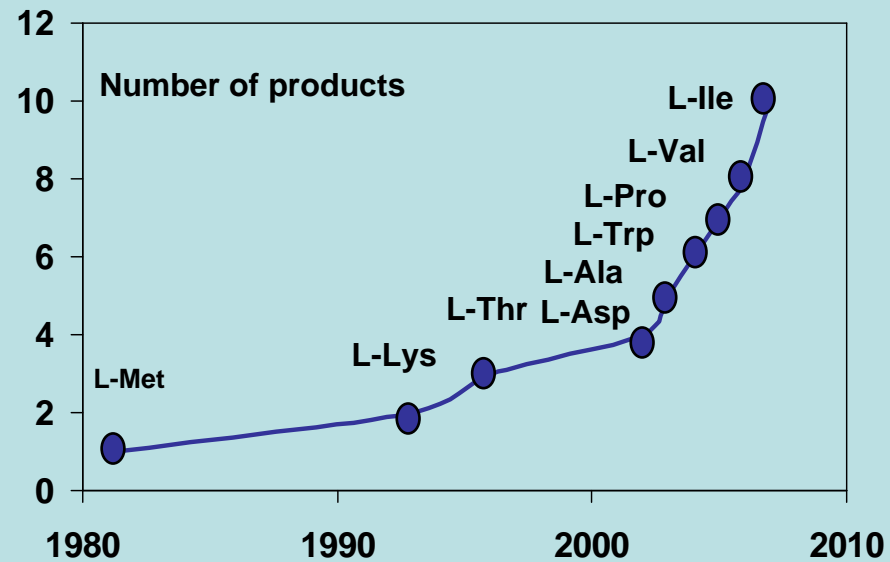

Success factor V: Innovation & partnering excellence



Deutsch-Brasilianische Wirtschaftstage 2008
Encontro Econômico Brasil-Alemanha 2008

Example open innovation

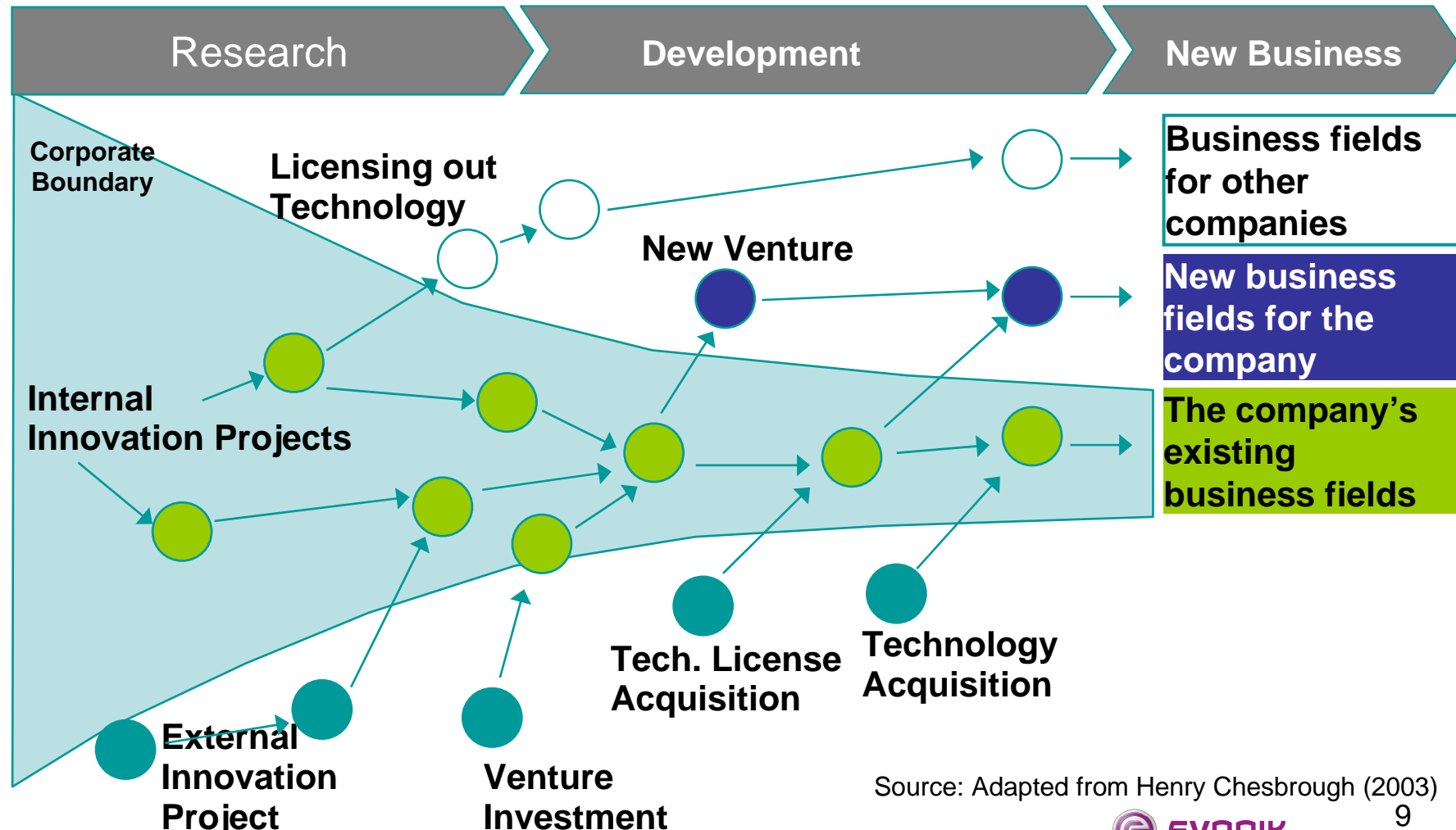

Michael Dröscher

Source: Adapted from Henry Chesbrough (2003)



Success factor V: Innovation and partnering excellence



Deutsch-Brasilianische Wirtschaftstage 2008
Encontro Econômico Brasil-Alemanha 2008

Example SusChem

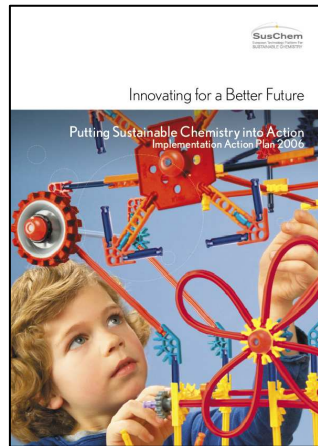

The European Technology Platform for Sustainable Chemistry

Started by chemical industry and academia with a strong backing from the commission

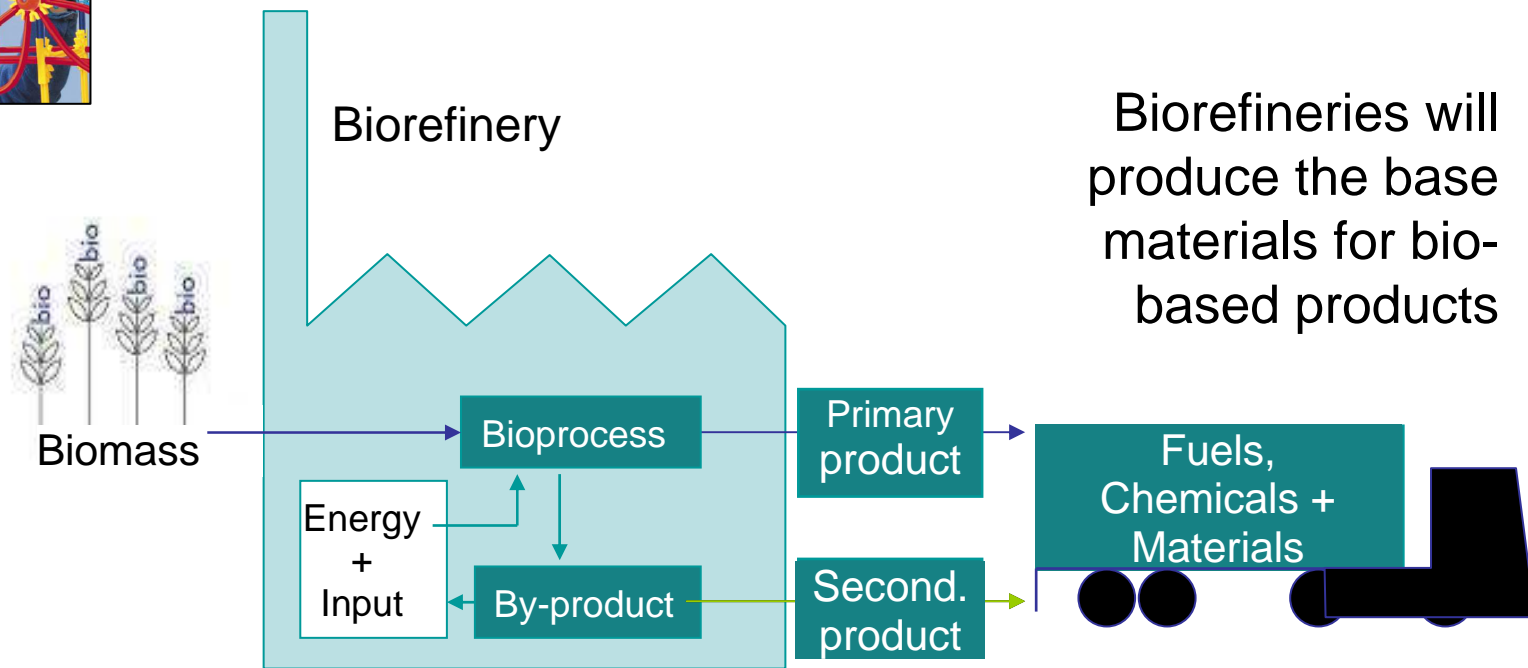

Summary Success factors



Deutsch-Brasilianische Wirtschaftstage 2008
Encontro Econômico Brasil-Alemanha 2008



I. Competitive raw materials

II. Cutting-edge science & technology



III. Solid intellectual property

IV. Relevant lead markets

V. Innovation and partnering excellence

